

E1 Band High Gain, High Power Amplifier



Product Overview

AT-PA-6879-3828 is high gain high power amplifier with +26dBm output power in the frequency of 68-79GHz. The DC power requirement is +5/1600mA. The module is with a standard WR-12 waveguide.

The power amplifier has high gain, high linearity, low input/output return loss and flat gain response.

It can also be used from 68-81Hz with some variation of performance.

More information, please visit www.atmicrowave.com

Advantages

- ✓ Frequency: 68-79GHz
- ✓ Psat:+28dBm
- ✓ Small signal gain: 38dB
- ✓ Single Positive Supply

Application

- ✓ E Band Point to Point Communication
- ✓ FOD (Foreigner Objects Debris)
- ✓ Test Equipment
- ✓ ROF (RF Over Fiber)
- ✓ Radar System

Key Features

Parameter	Min	Typical	Max
Frequency		68-79GHz	
Gain	35	38dB	
Drain Supply		+5V	+6V
Current/NO RF		1.6A	
Idd/Psat		2.3A	
P1dB		+26dBm	
Psat	+27	+28dBm	
Input Return Loss		-5 dB	
Output Return Loss		-5 dB	
Spec Temp		25C	





AT-PA-6879-3828

68-79GHz Power Amplifier, $P_{sat}=+28dBm$

Mechanical Information

Item	Description
Input Port	WR-12
Output Port	WR-12
Case Material	Copper
Finish	Gold Plated
Weight (Without Heatsink)	280g
Size:	See outline

Absolute Maximum Ratings Table

Parameter	Value
Drain Supply	+7V
RF Input Power	+15dBm
Operating Temperature	0 to +50C
Storage Temperature	-65 to +150C

Caution:

Please pay attention to the case temperature. If case temperature exceed higher than +50C, heat sink and fan are required, or the amplifier may be damaged.

Notes:

1. Datasheet may be changed according to update of MMIC, Raw materials , process, and so on.
2. This data is only for reference, not for guaranteed specifications.
3. Please contact AT Microwave team to make sure you have the most current data.



Test Data:

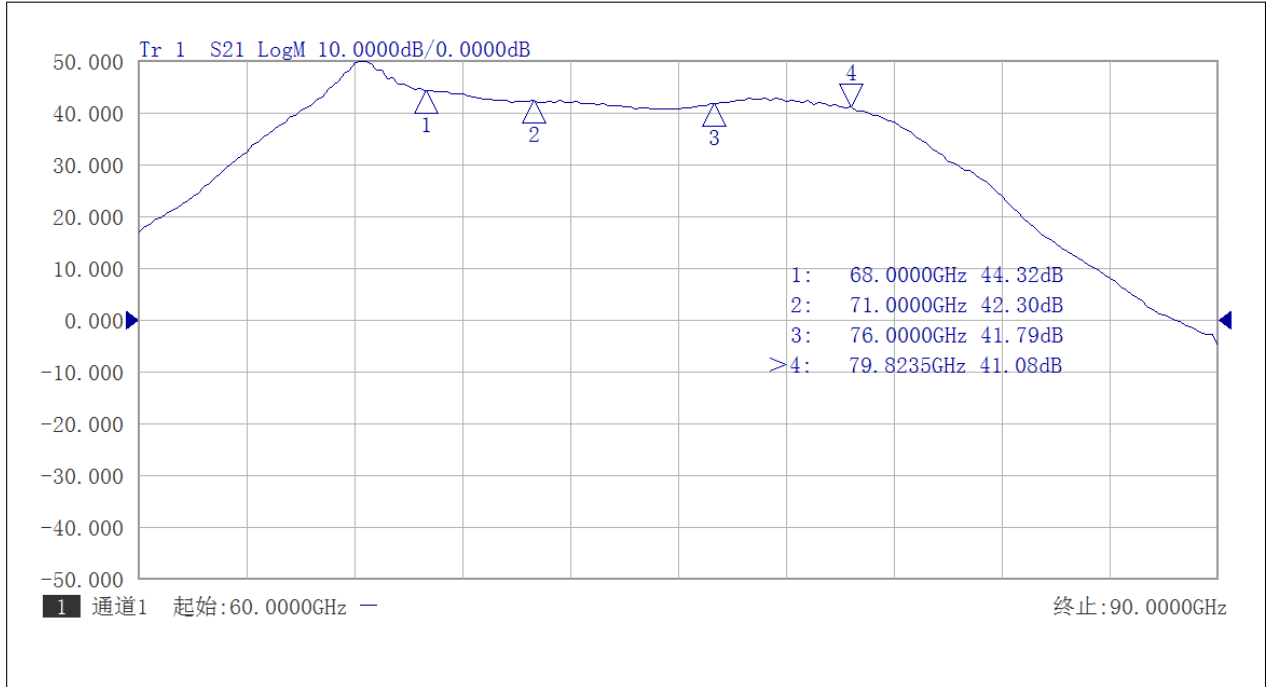

Gain vs Frequency 60-90GHz

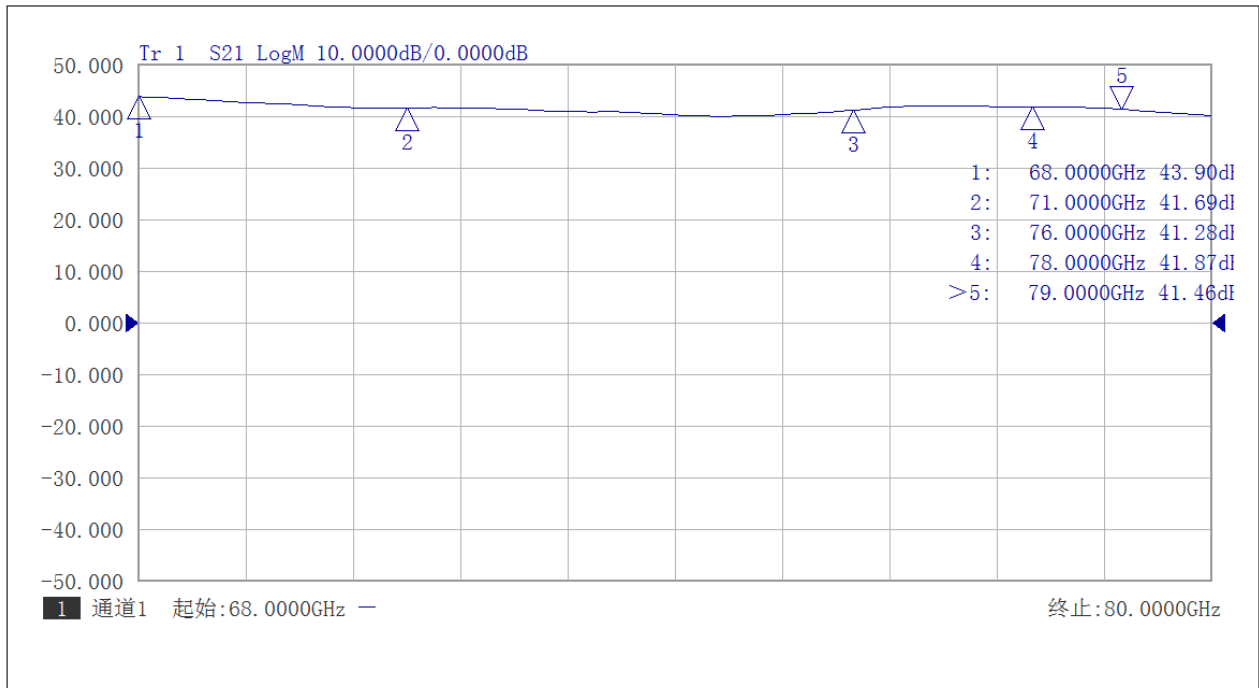

Gain vs Frequency 68-80GHz



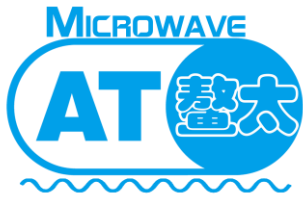

AT-PA-6879-3828

68-79GHz Power Amplifier, Psat=+28dBm

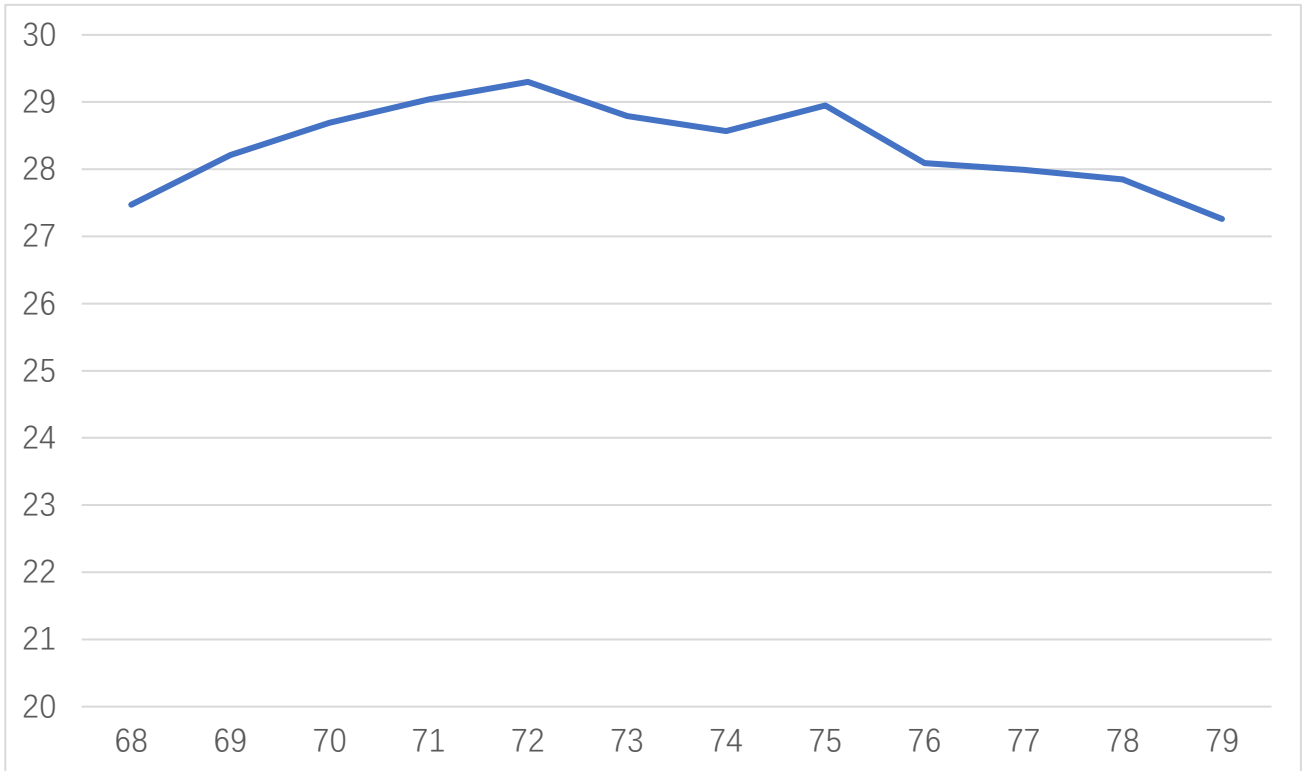

Pout vs Frequency



E Band 60-90GHz

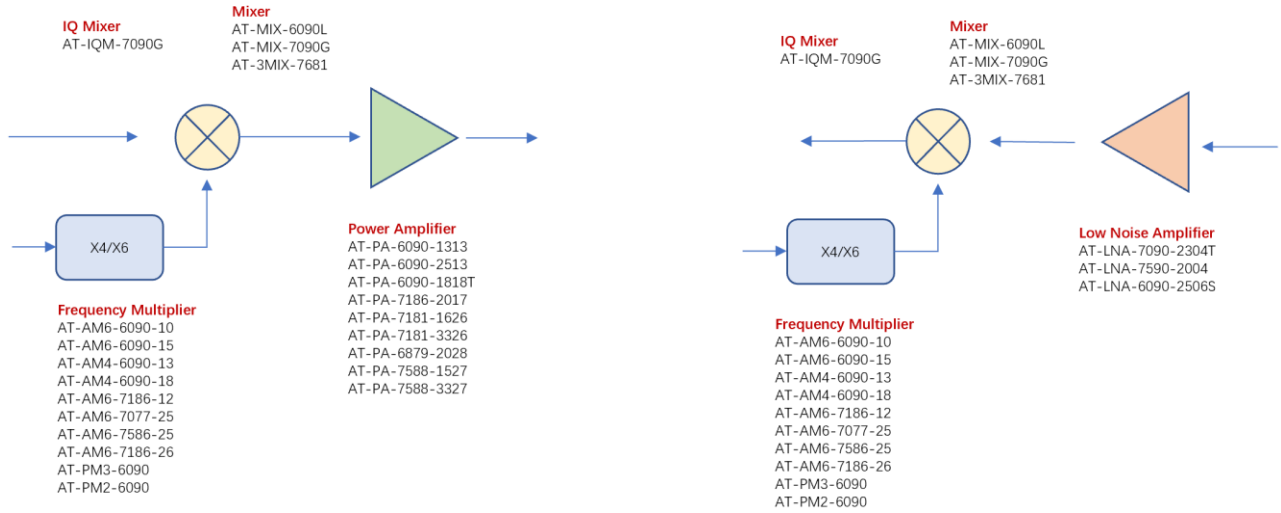

Dimension:(unit in mm)

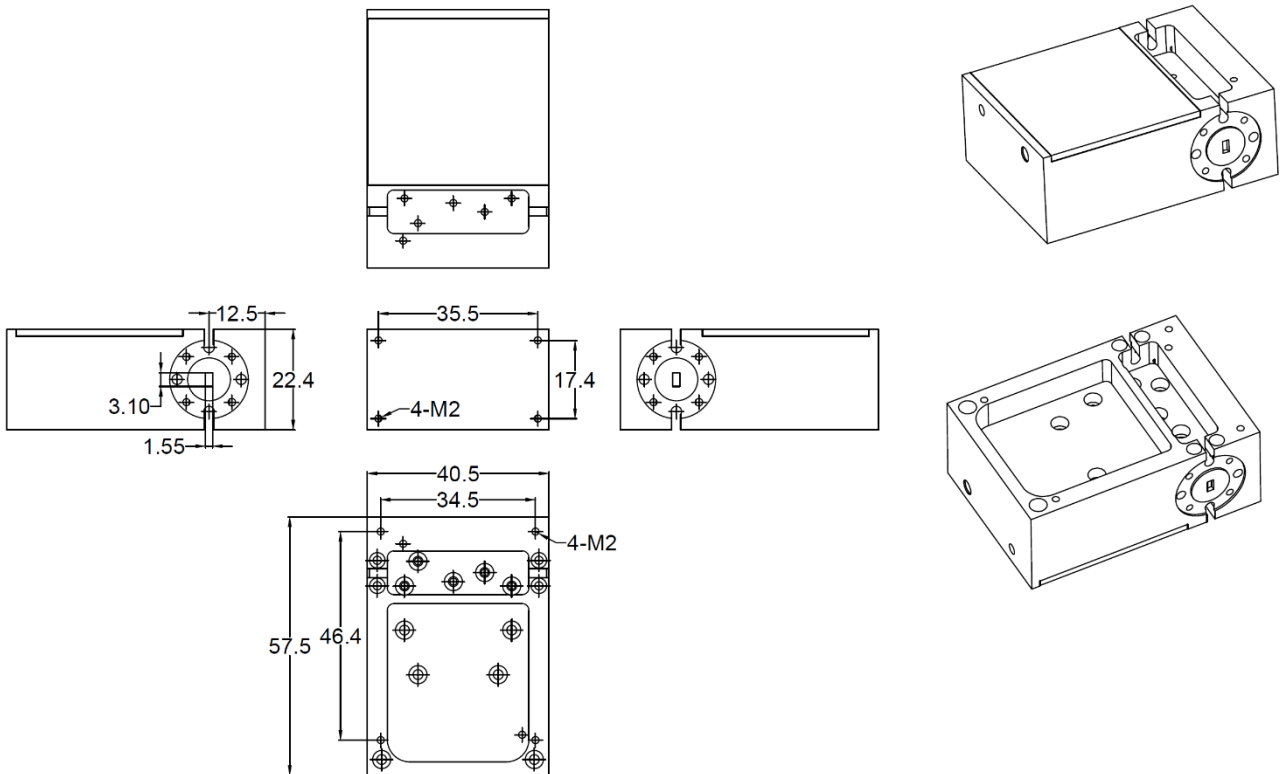

Heatsink required during operation



Dimension with heatsink:(unit in mm)

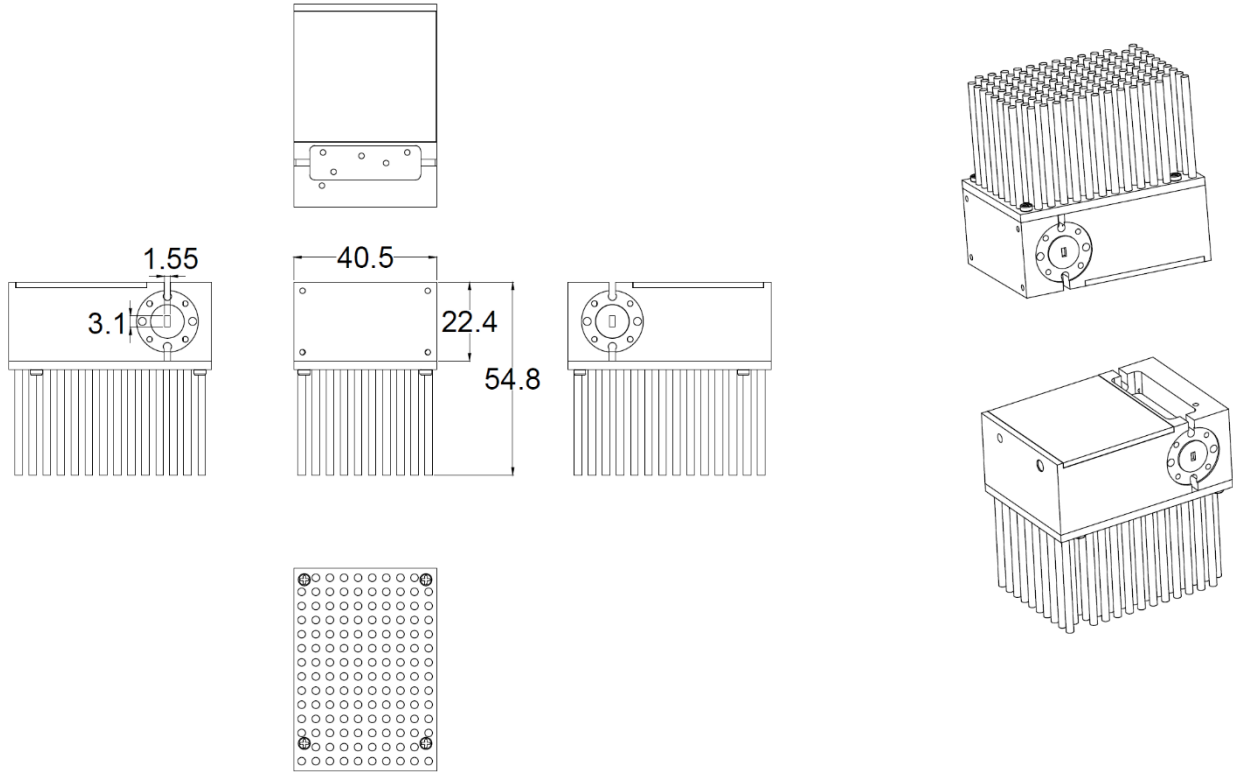

Dimension with Heatsink

AT Microwave provides a heatsink in default if P_{out} is higher than +20dBm
Customer can remove the heatsink easily and use their own heatsink if need.

